



Enitra Sp. z o.o.
 ul. 1 Maja 62, 58-300 Walbrzych
 Tel. (0-74) 887-02-20 do 25
 Fax (0-74) 843-91-40; 887-02-23
 e-mail: enitra@enitra.pl
 internet: www.enitra.pl

**P U t i m i n g
 b e l t s e l e c t i o n
 s u r v e y**
 (simplified version)
 Zal. nr P.18-24

DATE

1. Type / pitch (PU)

T 2,5	T5	T10	T20	AT5	AT10	AT20	L	H	5M	8M

Belt dimensions

Width	Length	Number of teeth
B= [mm]	L= [mm]	Z = [pcs]

3. Splicing type:

Welding (- V-), FLEX (endless cord without connection point), Mechanical EMF



4. Cord type

Steel , Kevlar / aramide , INOX strengthened Flex (flexible for working on small diameters)

5. Inlay

Inlay's material	Colour	Hardness [ShA]	Thickness [mm]	Width [mm]

6. Perforation according to below patterns

	mm a= t=		mm a= b= c= d= e= t=
	a= b= c= d= t=		a= b= c= d= e=
	a= b= c= t=		a= b= c= d=

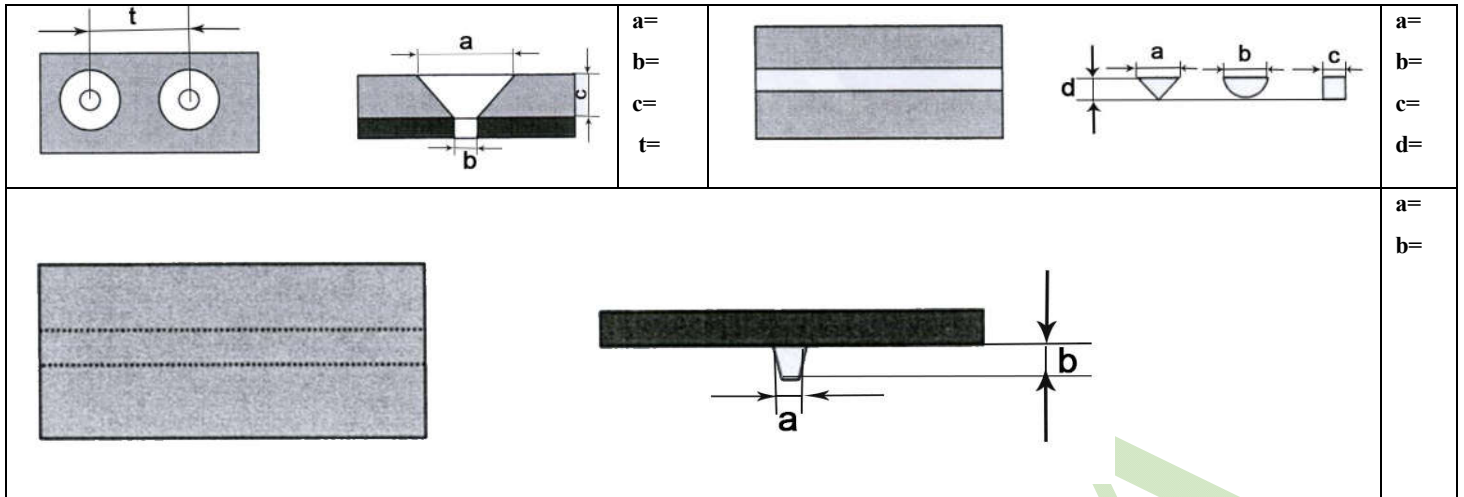

7.

Cleat	Shape <i>(please give dimensions and attach drawing)</i>	Width [mm]	Positioning towards the axis <i>(please attach the drawing)</i>	Quantity [pcs]
-------	---	---------------	--	-------------------

8. Mechanical trough grooving

- Trough location (*please add drawing*)
- Trough running width [mm]

9. Trucking guide

Profile 6x4 , Profile 8x 5 , Profile Z (10x6) , Profile A (13x8) , Profile B (17x11)

10. Additional equipment:

- Magnetic insert
- False teeth
- Steel insert for profile fixing onto belt

11. Additional data :

- Application
- Working conditions
- Pulley diameter without counter lection / Pulley diameter with counter lection [mm]

General Customer Data:

Name,Surnme..... Phone / Fax

Company Name

Address.....

Contact person.....